

7 STOOP DETAILS

1/4" = 1'-0"

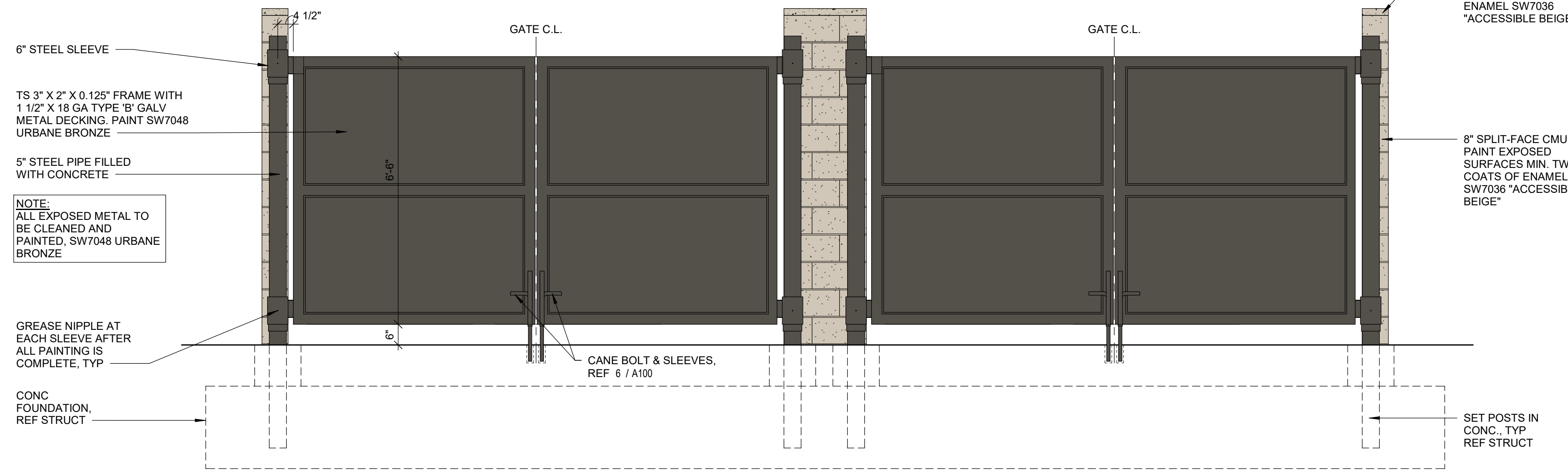

2 TRASH ENCLOSURE GATE ELEVATION

1/2" = 1'-0"

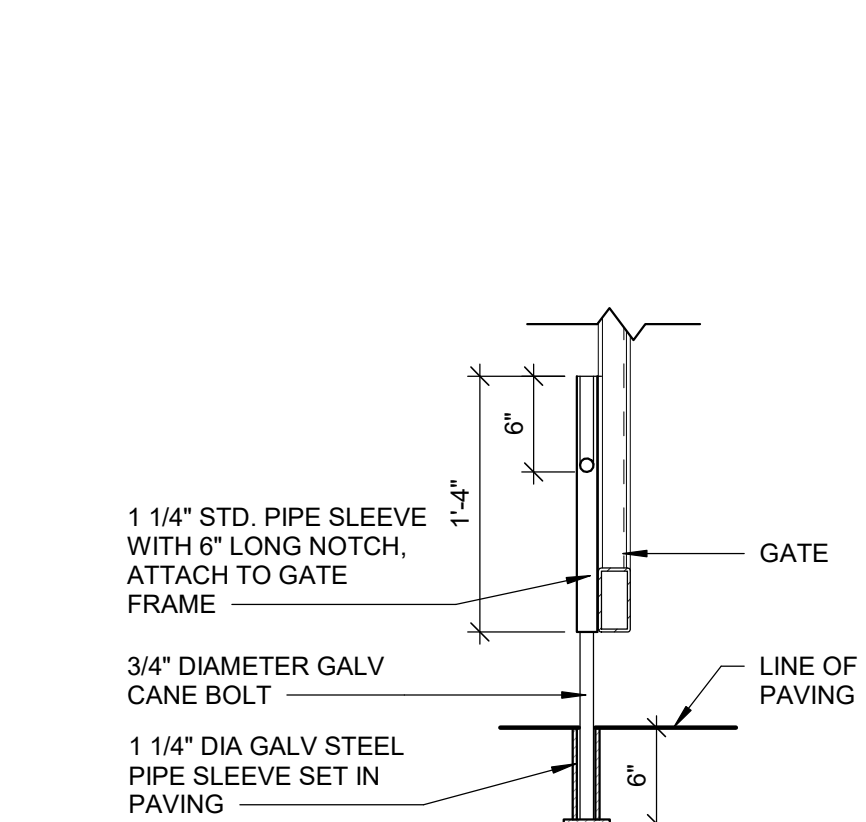

6 SECTION THROUGH GATE

1" = 1'-0"

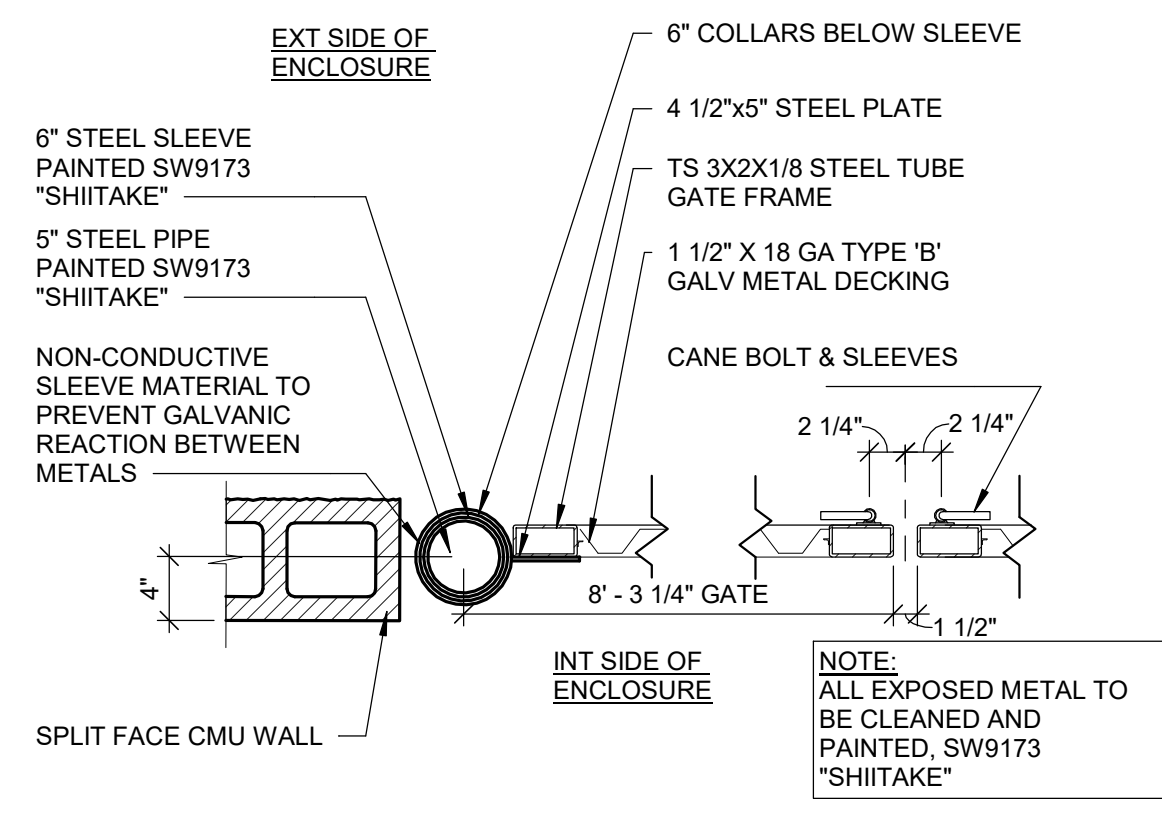

5 SECTION THROUGH GATE

1" = 1'-0"

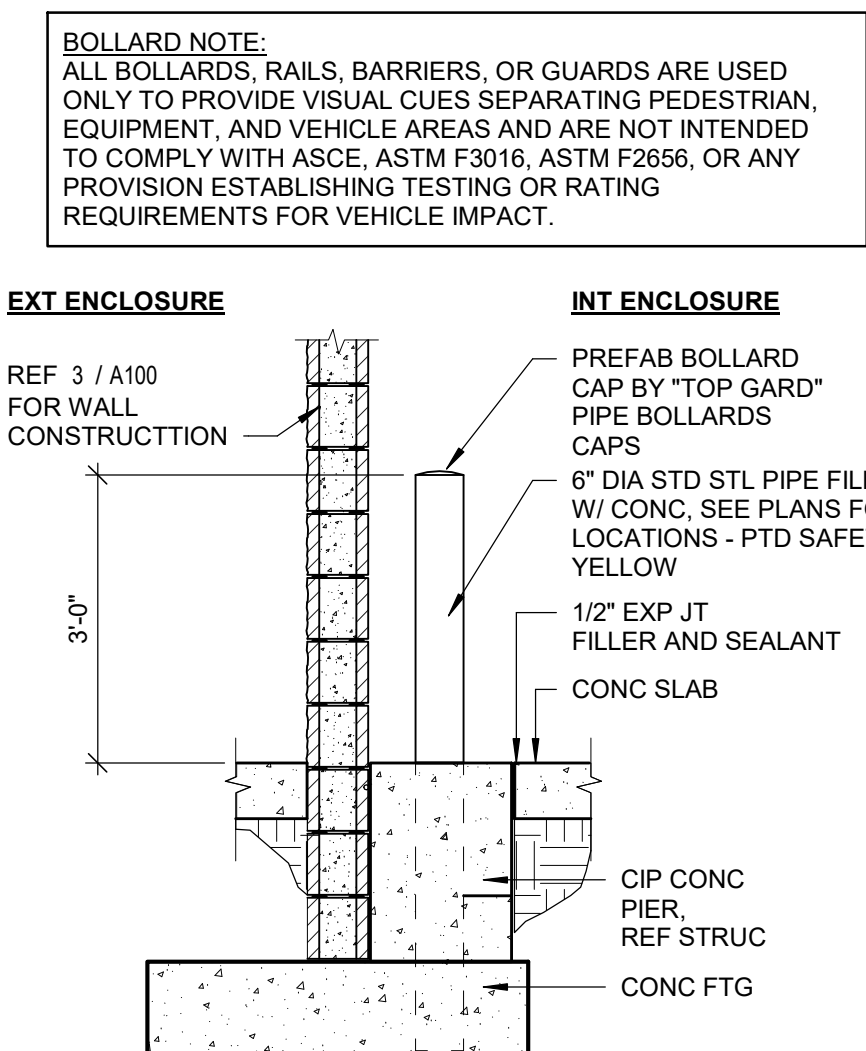

4 PIPE BOLLARD DETAIL

1/2" = 1'-0"

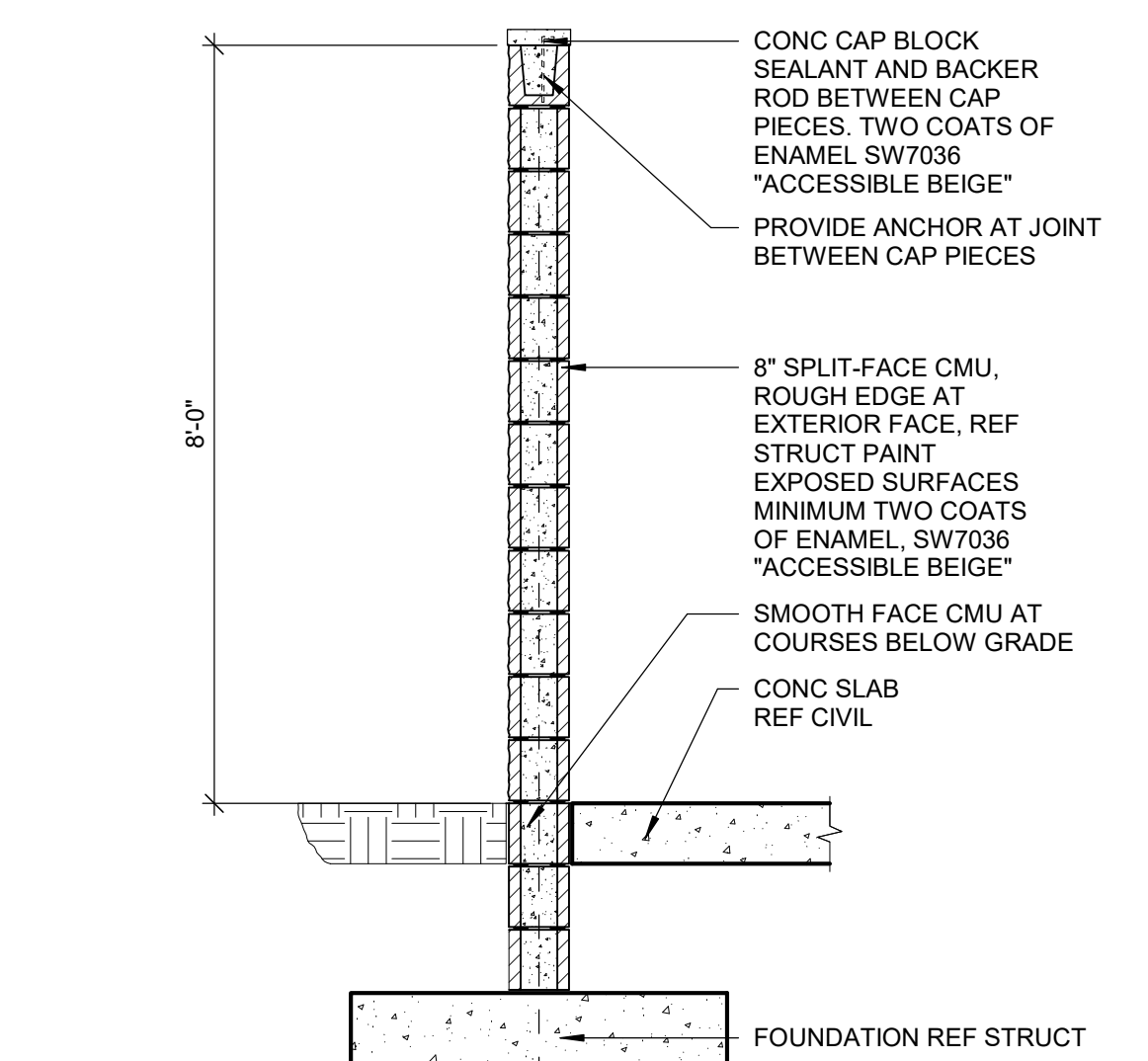

3 TRASH ENCLOSURE WALL SECTION

1/2" = 1'-0"

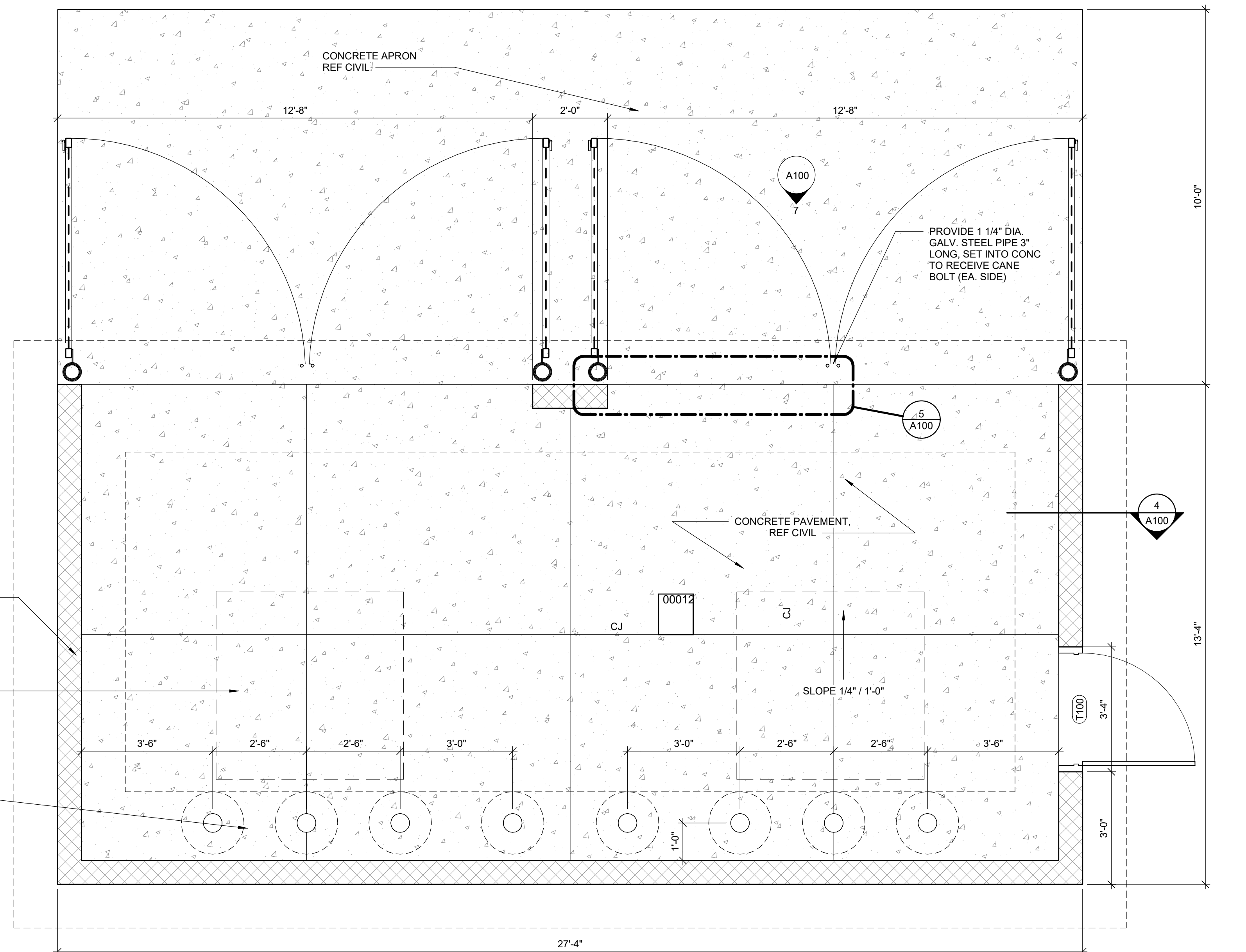

1 TRASH ENCLOSURE PLAN

1/2" = 1'-0"